

The Tess 100 system is a wire guided tension blind suitable for internal use on horizontal and sloping glazing. It has a single fabric roller incorporating the motor and tension mechanism and is supplied with universal mounting brackets suitable for top or back fixing and one continuous tension cable for ease of fitting.

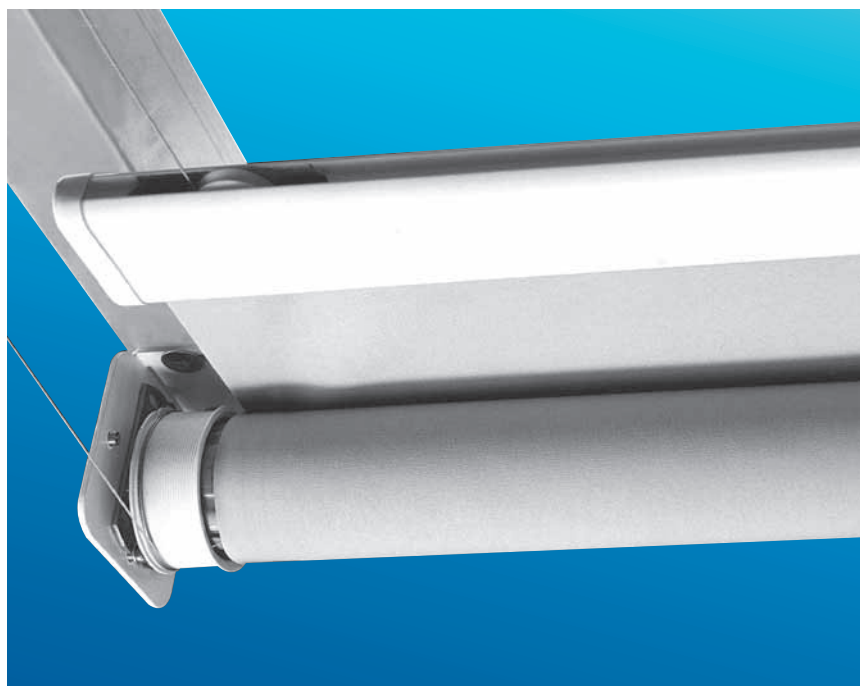

Technical specification

Model	T10775	
Maximum width	(m)	3
Maximum draw	(m)	6.5
Maximum fabric area	(m ²)	16
Basic weight	(kg)	7.5
+ per metre width	(kg)	4.2
Typical fixing load	(kg)	24
Maximum fixing load	(kg)	36
Motor torque	(Nm)	15
Motor speed	(min ⁻¹)	17
Motor current at 230V	(A)	0.6
Motor cable length	(m)	2.5
Temperature range	(°C)	-5 to +55
Maximum run time	(min)	4
Minimum fabric speed	(m/min)	5

Description

- an **85mm galvanized steel fabric roller tube** incorporating **motor and spring tension compensation cassette** to maintain **constant tension** throughout the travel.
- 6.5m capacity cable drums at each end of the tube to take up the continuous nylon-coated **stainless steel tension cable**.
- a gear-operated mechanical tension adjustment within one drum to enable the **fabric tension to be adjusted between 5 and 25kg**.
- all visible aluminium parts syntha pulvin **polyester powder-coated** in the system colour specified.

Details

Fabric Roller

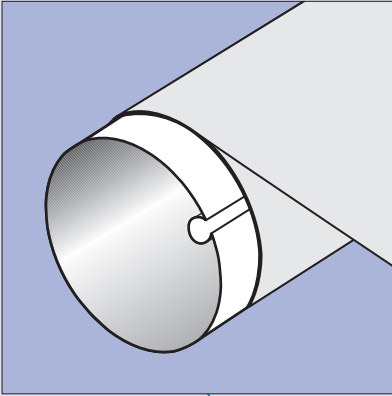

Universal mounting bracket

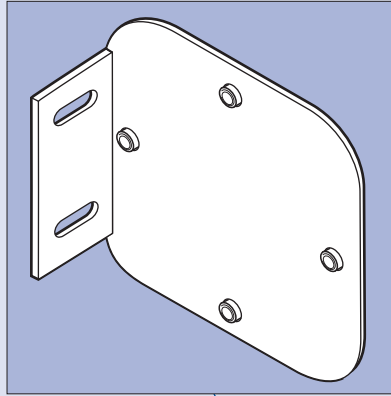

Relieving roller bracket

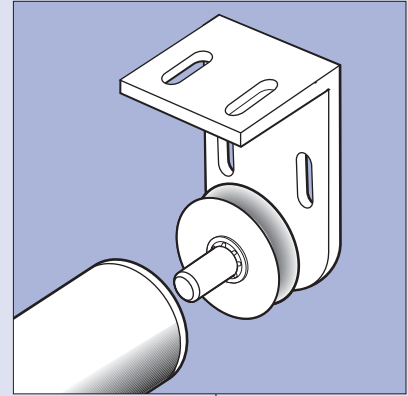

Motor position

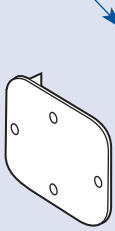

Hem bar

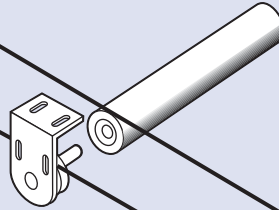

Relieving roller



Return pulley

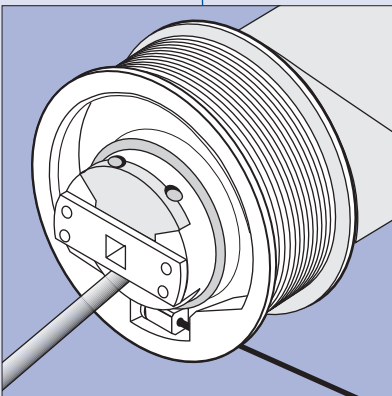

Motor with cable spool
(without mounting plate)

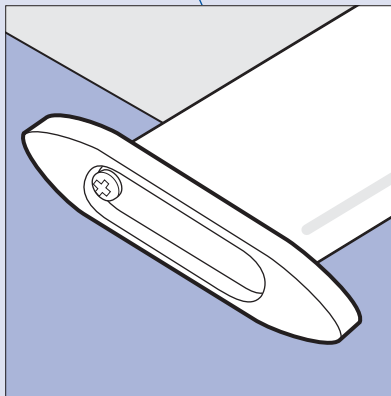

Hem bar end cap for system with
relieving roller

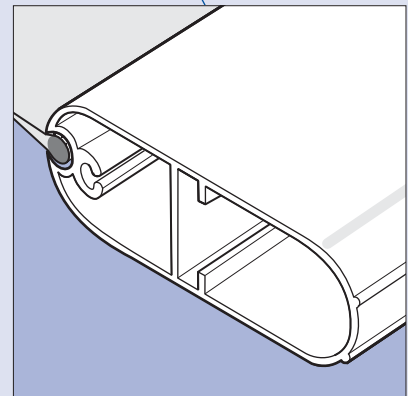

Hem bar

Installation examples

For full installation details see drawings GDP10738/01 and GDP11078/02

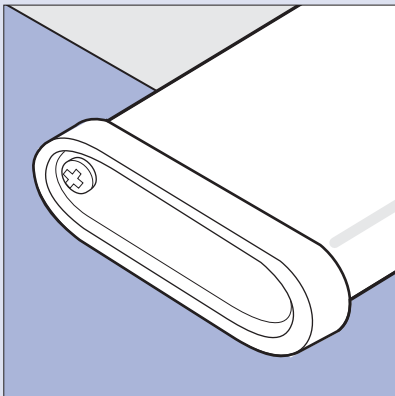

Hem bar end cap for system without relieving roller

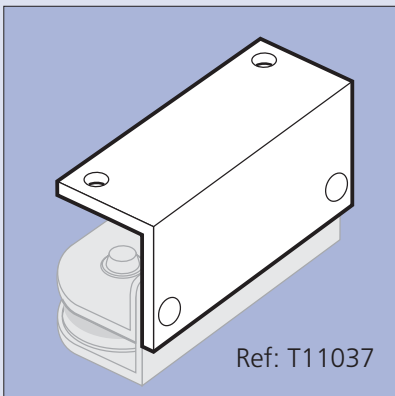

Additional return pulley fixing bracket for top fix

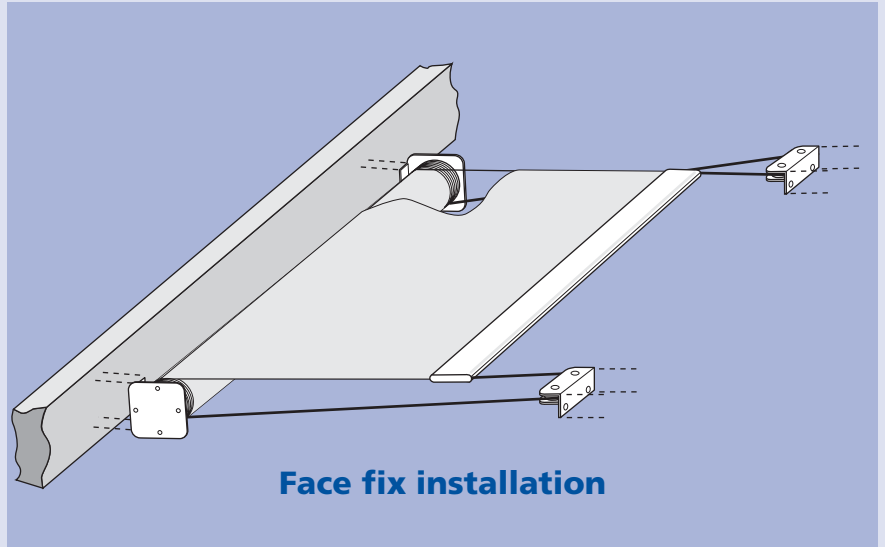

Face fix installation

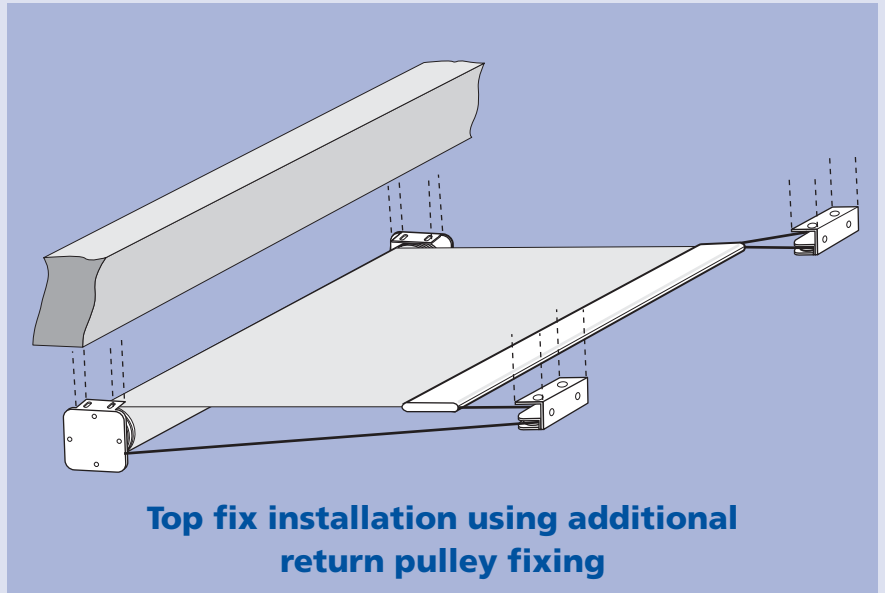

Top fix installation using additional return pulley fixing

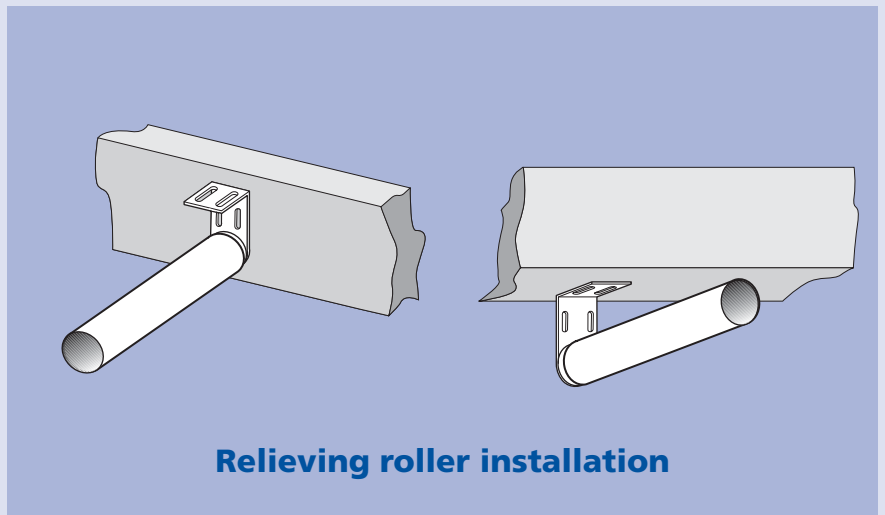

Relieving roller installation

Technical Specification

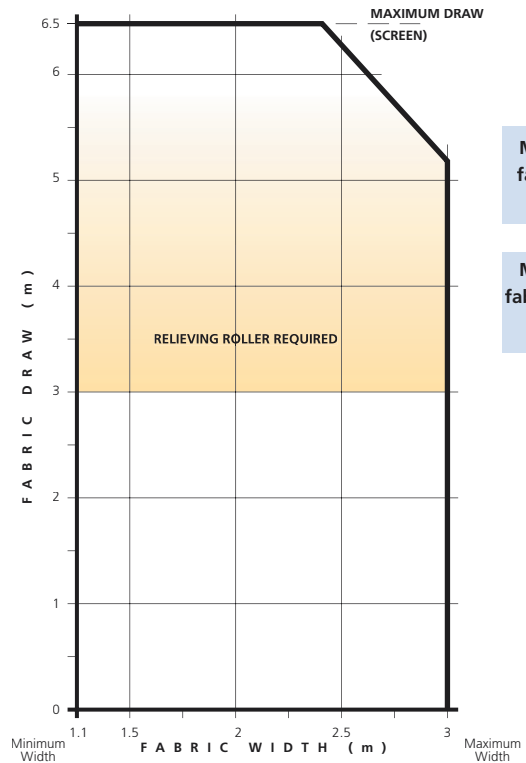
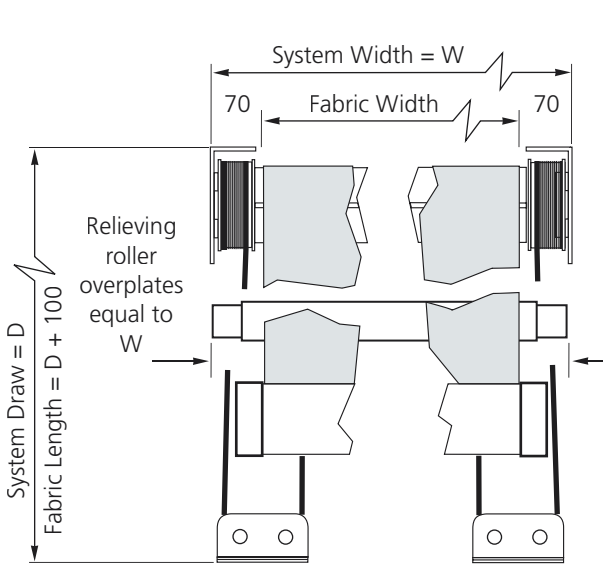
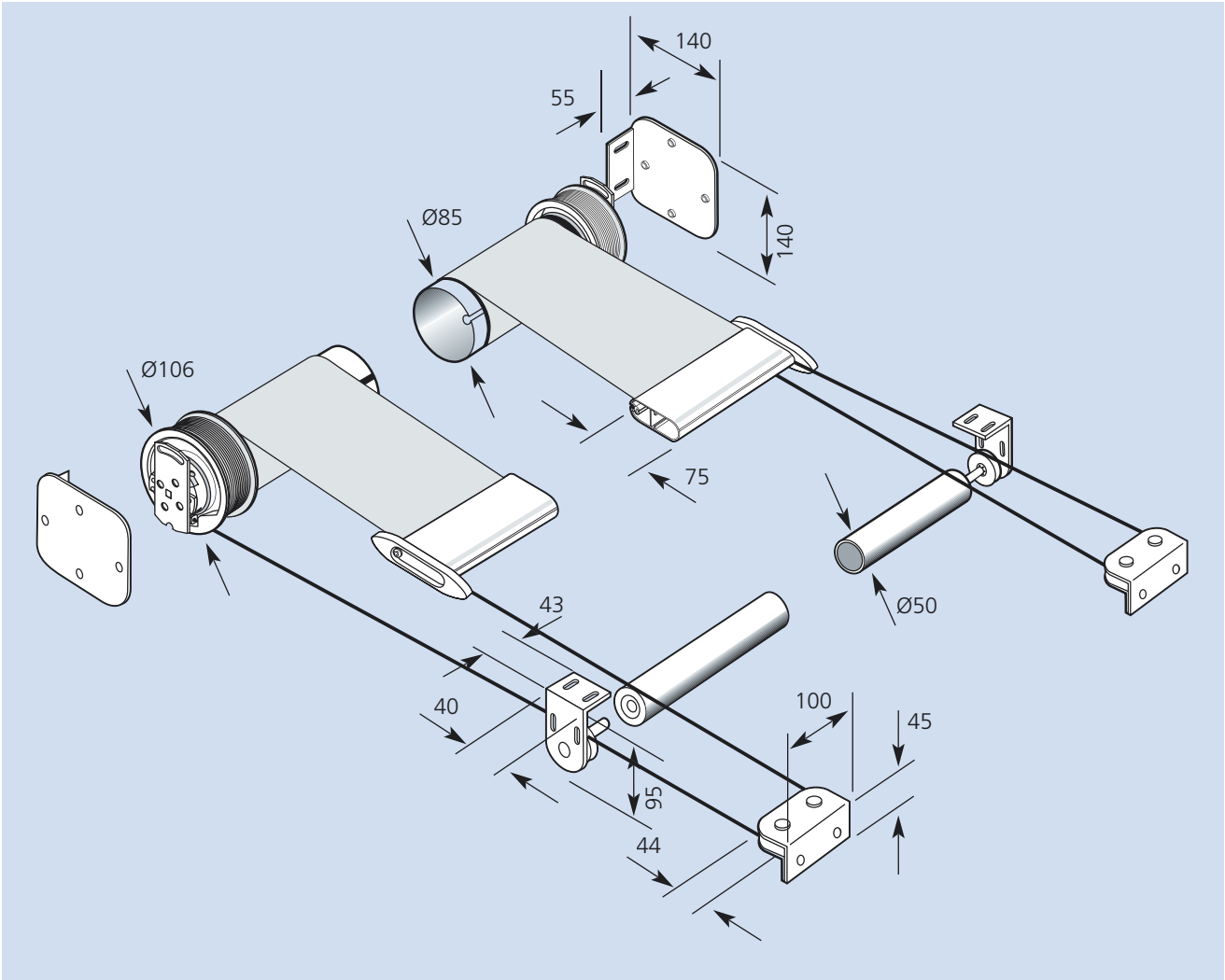

Maximum fabric area 16m²

Maximum fabric weight 450g/m²

Guthrie Douglas

LUXBEST

Vilholtevej 47
DK-8740 Brædstrup
Tlf +45 7575 3080 Fax +45 7575 3082
mail@luxbest.dk www.luxbest.dk



Assessed to ISO 9001: 2000 Certificate No 193