

The Tess 200 system is a wire guided tension blind suitable for internal use on large horizontal and sloping glazing. It has a fabric roller containing the motor and a take-up roller incorporating the tension mechanism, both of which are supplied mounted in a H-frame with one continuous tension cable for ease of fitting.



## Technical specification

Model Motor	T10241		
	Type 5	Type 6	
Maximum width	(m)	4	4
Maximum draw	(m)	9.6	18
Maximum fabric area	(m <sup>2</sup> )	38	60
Basic weight	(kg)	31	32
+ per metre width	(kg)	11	11
Typical fixing load	(kg)	48	48
Maximum fixing load	(kg)	72	72
Motor torque	(Nm)	30	55
Motor speed	(min <sup>-1</sup> )	17	17
Motor current at 230V	(A)	1.1	1.5
Motor cable length (m)	2.5	2.5	
Temperature range	(°C)	-5 to +55	-5 to +55
Maximum run time	(min)	4	4
Minimum fabric speed	(m/min)	7	7

## Description:

- a **127mm extruded aluminium fabric roller tube** incorporating the **motor**.
- a **steel take-up roller incorporating the spring tension compensation cassette** to maintain **constant tension** throughout the travel.
- **cable drums** on the take-up roller for the continuous nylon-coated **galvanized steel tension cable**.
- a gear-operated mechanical tension adjustment in the spring cassette to enable the **fabric tension to be adjusted between 15 and 50kg**.
- all visible aluminium parts **syntha pulvin polyester powder-coated** in the system colour specified.

# Details

Fabric Roller

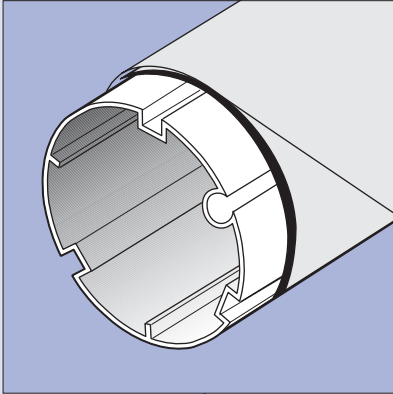

Mounting tee bolt

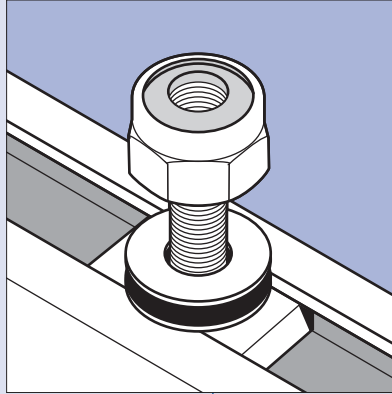

Relieving roller bracket

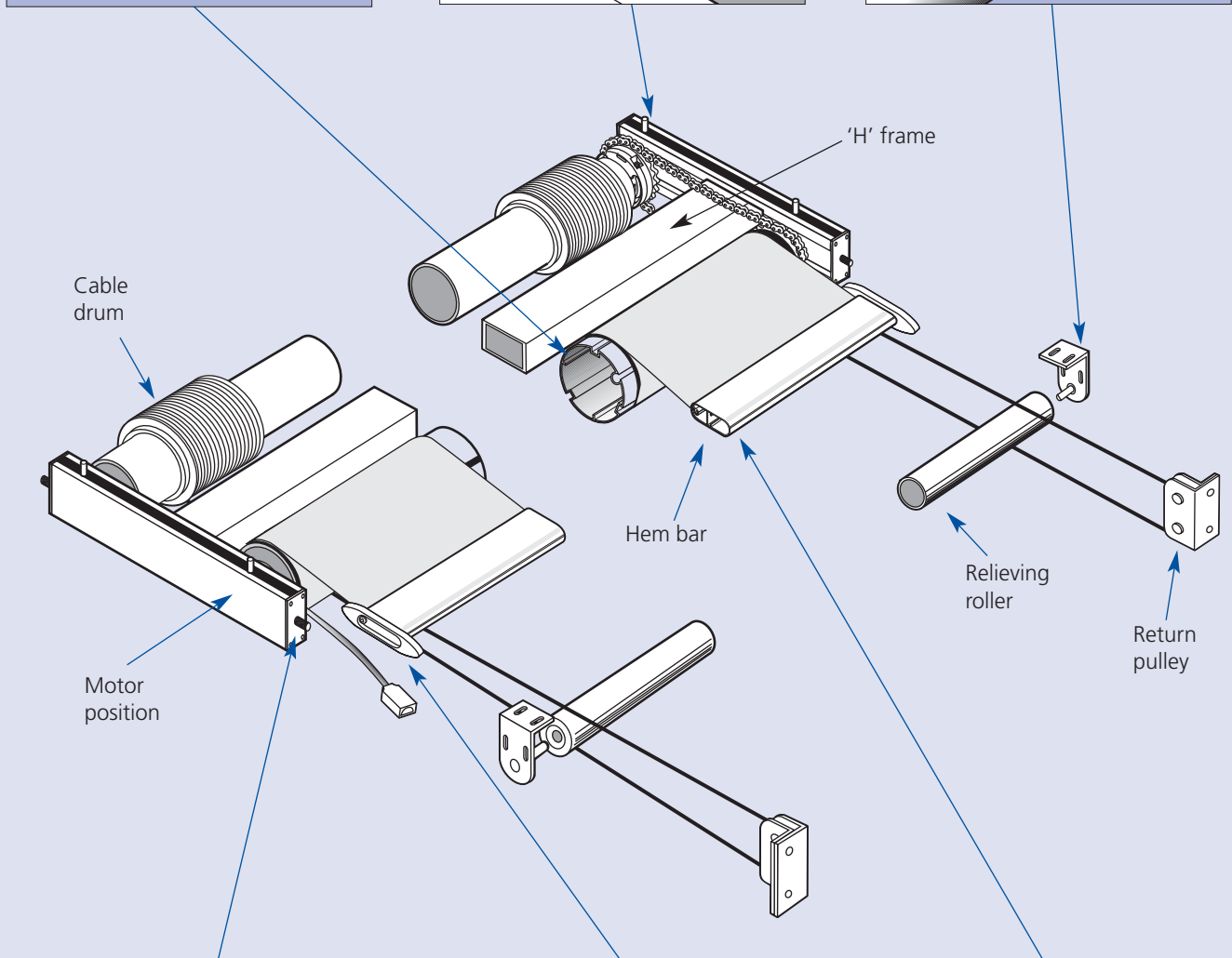
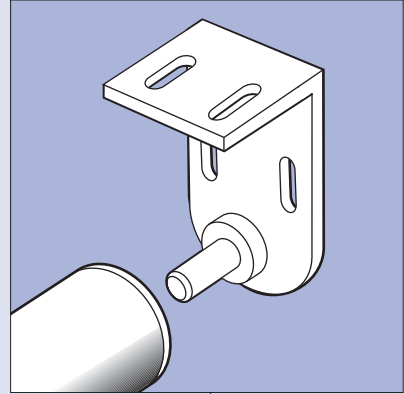

Cable drum

'H' frame

Motor position

Hem bar

Relieving roller

Return pulley

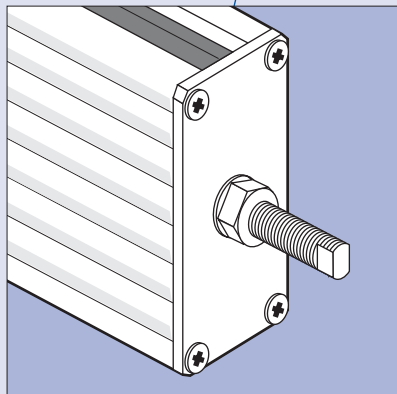

Tracking adjustment

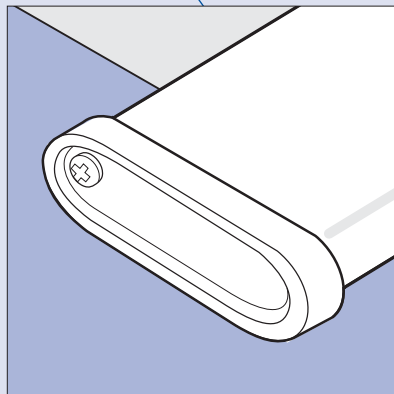

Hem bar end cap

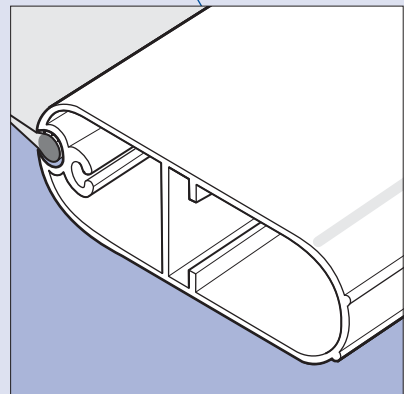

Hem bar

## Installation examples

For full installation details see drawings GDP10162/02, GDP11237/02 and GDP11268/02.

The mounting brackets shown are examples only and are not supplied as standard. For alternative mounting bracket designs please contact our sales department.

### Horizontal mounted

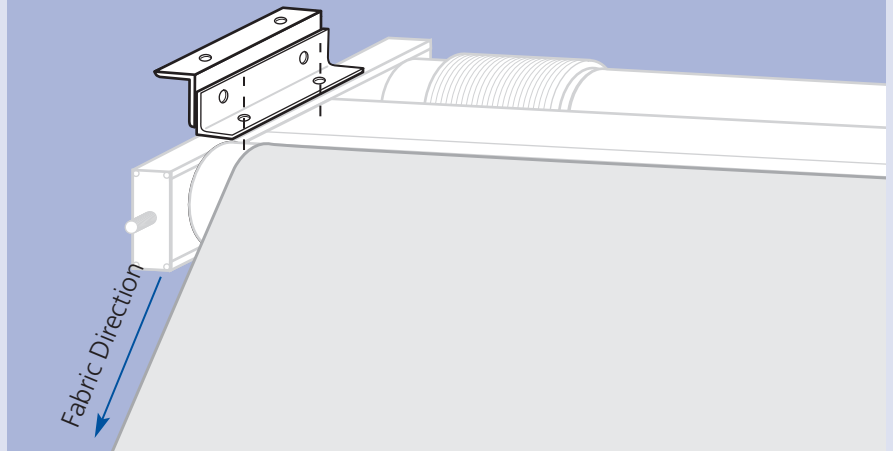

### Vertical mounted

Tracking adjustment needs to be built into mounting brackets

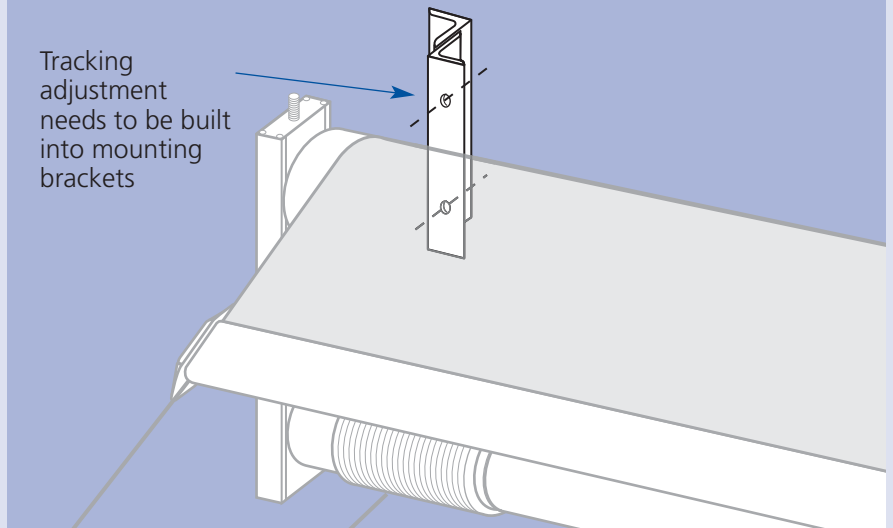

### Relieving roller installation

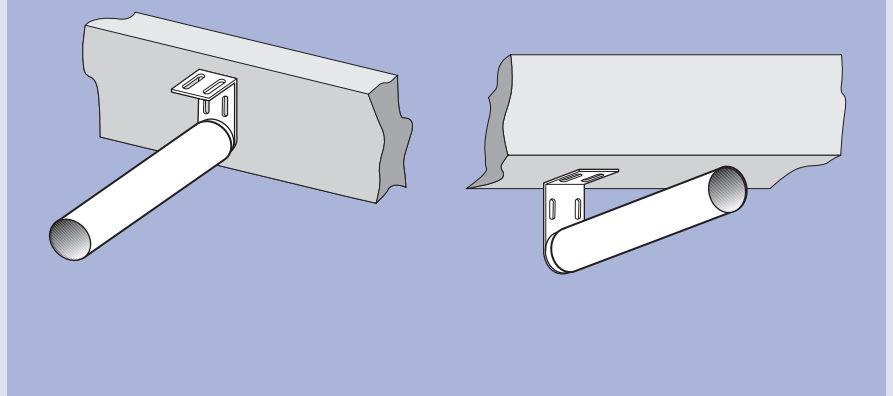

Dimensions

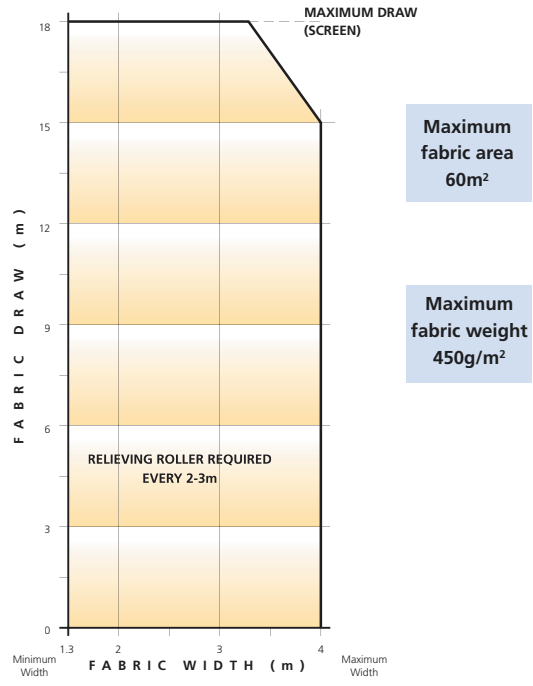
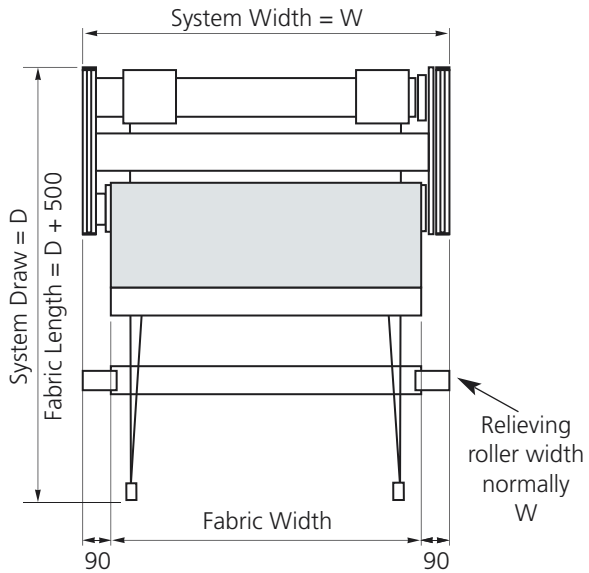
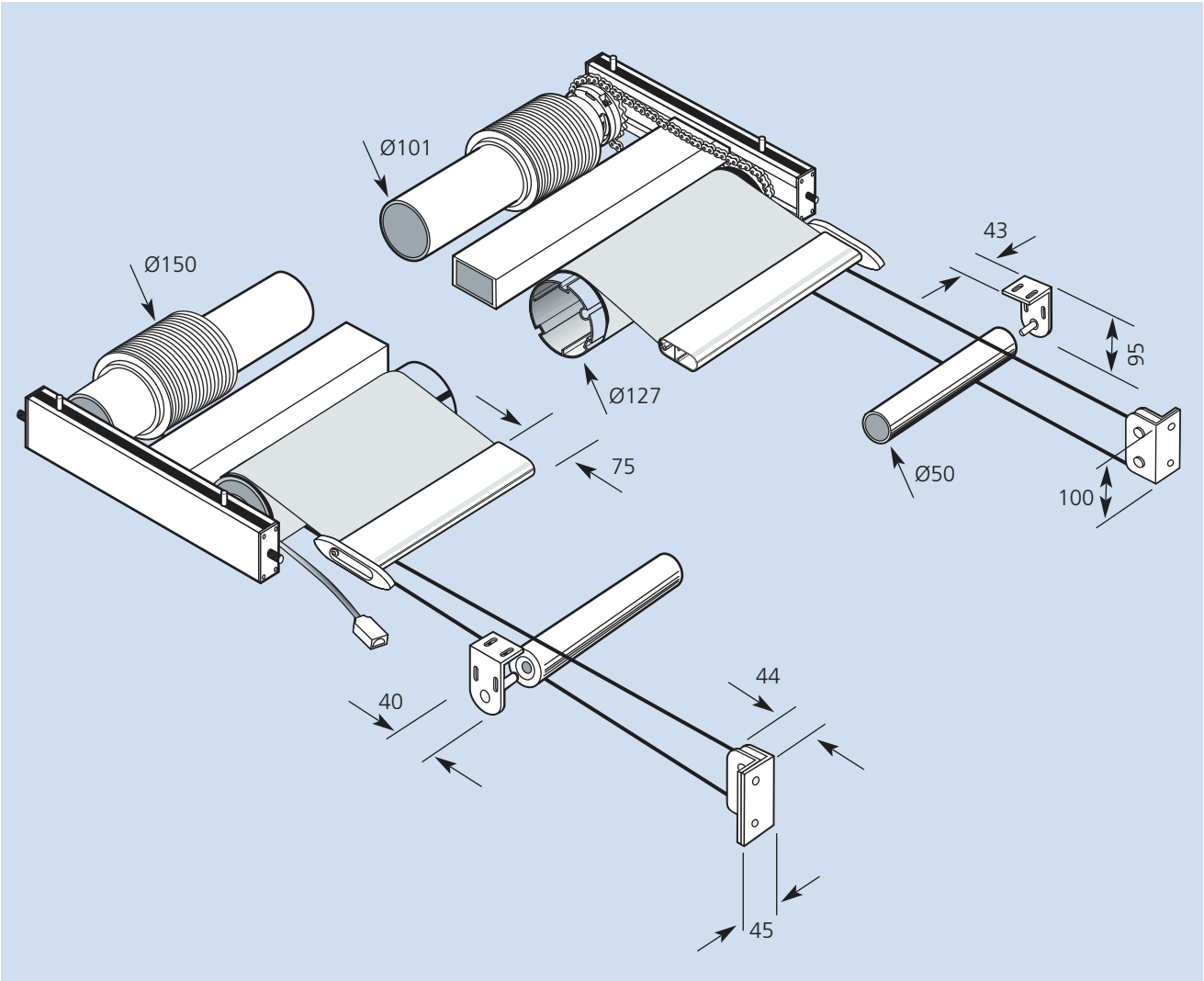

**Guthrie Douglas**

**LUXBEST**

Vilholtevej 47  
 DK-8740 Brædstrup  
 Tlf +45 7575 3080 Fax +45 7575 3082  
 mail@luxbest.dk www.luxbest.dk



Assessed to ISO 9001: 2000  
 Certificate No 193